

# BRTF - Body Related Transfer Functions for Whole-Body Vibration Reproduction Systems

Ercan Altinsoy<sup>1</sup>, Sebastian Merchel<sup>2</sup>

Chair of Communication Acoustics, Dresden University of Technology, Germany  
<sup>1</sup>ercan.altinsoy@tu-dresden.de <sup>2</sup>sebastian.merchel@tu-dresden.de

## Introduction

Interest in human responses to whole-body vibration has grown, particularly due to the increasing usage of vehicles, e.g. cars, trucks, and airplanes etc. Therefore both fundamental research studies and comfort studies have become a focus of attention in recent years. Many experimental studies in laboratory use reliable electrodynamic or hydraulic systems (simulators), which produce vibrations in one (vertical, z) or in three (x,y,z) directions. The requirements for such a system include a linear-frequency response, no cross-talk between different axes, no system harmonics and to be as silent as possible to avoid interaction between sound and vibration. The principal aspects of the authentic whole-body-vibration reproduction and the simulation systems show similarity with binaural technique and audio reproduction systems.

If binaural recorded signals are played back via headphones, the transfer characteristic of the reproduction system has to be compensated for. Unfortunately the transfer characteristic depends not only on the transducer itself, but also on mounting conditions and individual properties of the respective ear [1]. This is similar with reproduction systems for whole body vibration. The transfer characteristic depends to a great extent on the individual body properties, e.g. weight, body mass index, adipose. For fundamental scientific studies or comfort studies it is required to present the same stimulus (amplitude and frequency) to all subjects. This is only possible by taking into account individual equalization filters which are based on the individual body properties of each subject and the specifications of the reproduction system.

The structure of an electrodynamic shaker has similarity with a dynamic loudspeaker (Fig. 1). In the middle of the shaker is a coil, suspended in a fixed radial magnetic field. When a current is passed through this coil, an axial force is produced in proportion to the current. This force is transmitted to a table structure on which the test person is seated. Three modes of vibration dominate the mechanical response [2]. At very low frequencies, the compliant isolation mounts allow the entire shaker to move as a rigid body with almost no relative motion between the components. In the middle operating range (10 to 40 Hz, typical) the suspension mode dominates. In this frequency range, table and coil move together relative to the shaker body. At high frequencies, the table-person system has some resonances.

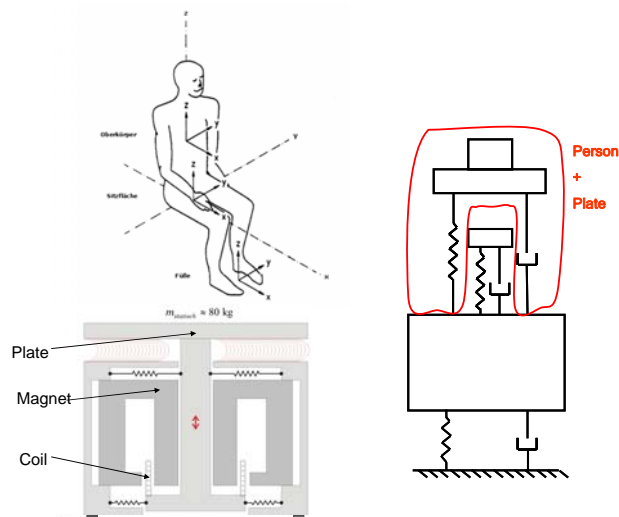

**Figure 1:** Electrodynamic exciter called shaker and an equivalent mechanical circuit of the shaker & person system. A simplified resonance model is used for shaker and person.

All electrodynamic exciters have similar transfer functions and acceleration-frequency characteristics, which are based on typical electro-mechanical properties of the used materials [3].

## Investigations

In this study body related transfer functions (BRTFs) of 40 subjects are measured using an electro-dynamic excitation system. The system is capable of producing vertical vibrations in a frequency range from 5 Hz to 1000 Hz. A schematic view of the system is shown in Fig. 1. The excitation signals are generated by Artemis 8.0 software package from HEAD acoustics running on a PC. The generated signals are then transmitted from the RME Hammerfall Multiface II soundcard via Alesis RA 150 amplifier to the electrodynamic shaker (VEB 11076). The transfer function of the system is measured with white noise as input vibration signal in vertical direction in a frequency range from 4 to 500 Hz. A semi-rigid pad with a triaxial accelerometer (B&K 4322) is used in this measurement and placed between the seat and the subject. The data (vibration at the body-seat interface and amplifier input) for the transfer functions are measured by HEAD Recorder software. In addition to the BRTF measurements anthropometric data of the subjects are collected.

Parameter	Range
Weight	53 kg - 109 kg
Adipose	5% - 35%
Body-Mass-Index	18 - 30
Age	19 - 57

**Table 1:** Anthropometric and other personal data of the subjects

The body related transfer functions of 40 subjects can be seen in Figure 2 (input signal: amplifier input: V; output signal: vibration at the body-seat interface:  $m/s^2$ ).

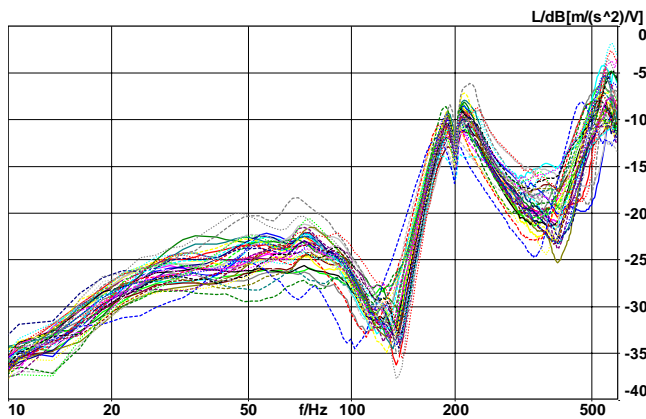
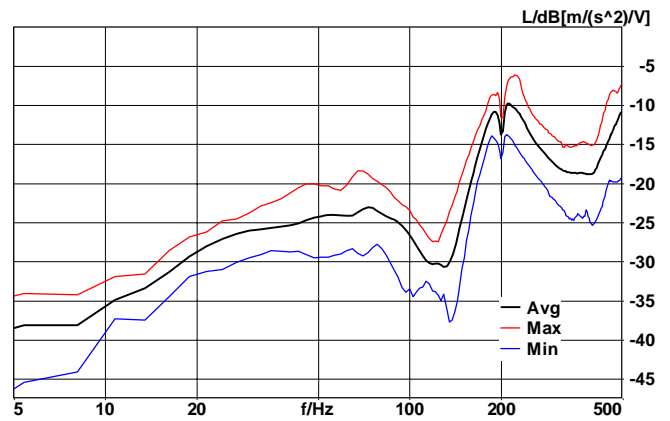

**Figure 2:** Body Related Transfer Functions of 40 Subjects measured in vertical direction.

Two different resonance frequencies are observable in the transfer function measurements. The first resonance is in the frequency range from 100 Hz to 150 Hz and the second resonance is in the frequency range from 180 Hz to 220 Hz. These resonance frequencies are the results of table-person interaction. An increase of the subject's weight results with a decrease in resonance frequency. The adipose and BMI values have an influence on the amplitude range of the transfer functions.

One aspect is the definition and creation of an average body transfer function representing a "best matched body". The average, the maximum and the minimum values of the body related transfer functions for 40 subjects can be seen in Figure 3.

The Just Noticeable Difference thresholds for vertical whole-body-vibrations in level are about 1.5 dB [3]. The amplitude differences between the maximum and the minimum values of the BRTFs are higher than the respective Just Noticeable Level Difference thresholds. Therefore an average body transfer function representing a "best matched body" is not suitable particularly for fundamental research studies but also for comfort studies.



**Figure 3:** The average, maximum and minimum values of the measured forty Body Related Transfer Functions.

## Conclusion

In this study, Body Related Transfer Functions are introduced for whole-body vibration reproduction systems and the importance of the individual transfer functions for whole-body vibration perception is discussed. One aspect was the definition and creation of an average body related transfer function representing a "best matched body". Another topic was the influence of the body properties on the transfer function characteristic.

The results show that the transfer characteristic depends to a great extent on the individual body properties, e.g. weight, body mass index, adipose. Therefore the individual transfer functions should be taken into account for whole-body vibration perception investigations.

## Acknowledgment

The authors want to thank Mr. J. Landgraf for his support to develop the electrodynamic excitation system for this study and valuable discussions and Prof. U. Jekosch for her support. Thanks also those who participated in our measurements.

## References

- [1] Hammershøi, D. & Møller, H.: Binaural Technique – Basic Methods for Recording, Synthesis, and Reproduction. In: Blauert, J. (ed) Communication Acoustics. Springer-Verlag, Berlin, Heidelberg, pp. 223-254, 2005.
- [2] Lang, G.F. & Snyder, D.: Understanding the Physics of Electrodynamic Shaker Performance. Sound and Vibration. October, 2001.
- [3] Bellmann, M.: Perception of whole-body vibrations: From basic experiments to effects of seat and steering-wheel vibrations on the passenger's comfort inside vehicles. Ph.D. Thesis. Carl von Ossietzky Universität Oldenburg, 2002.
- [4] Morioka, M. & Griffin, M.J.: Difference thresholds for intensity perception of whole-body vertical vibration: Effect of frequency and magnitude. J. Acoust. Soc. Am. 107(1). pp. 620-624, 2000.